

Cat® Lift Trucks.

Your partner in materials handling.

DP/GP40N - DP/GP45N					DP/GP40N		DP/GP45N	
Mast Type	h3	h1	h4	h2/h5	Q @ c = 500mm	Q @ c = 600mm	Q @ c = 500mm	Q @ c = 600mm
	mm	mm	mm	mm	kg	kg	kg	kg
Simplex	3000	2170	4130	150	4000	3500	4500	4000
	3300	2320	4430	150	4000	3500	4500	4000
	3700	2520	4830	150	4000	3500	4500	4000
	4000	2700	5130	150	4000	3500	4500	4000
	4500	3000	5630	150	4000	3500	4500	4000
	5000	3250	6130	150	3850	3500	4500	4000
	5500	3500	6630	150	3050	3050	3600	3400
	6000	3750	7130	150	2400	2400	2700	2700
Duplex	3000	2170	4130	1090	4000	3500	4500	4000
	3300	2320	4430	1240	4000	3500	4500	4000
	3700	2520	4830	1440	4000	3500	4500	4000
	4100	2700	5190	1620	4000	3500	4500	4000
Triplex	3700	1950	4830	870	4000	3500	4500	4000
	4000	2050	5130	970	4000	3500	4500	4000
	4360	2170	5490	1090	4000	3500	4500	4000
	4700	2285	5830	1200	3900	3500	4500	4000
	5050	2400	6180	1320	3800	3500	4500	4000
	5500	2550	6630	1470	3050	3050	3600	3500
	6000	2750	7130	1670	2400	2400	2700	2700
	6500	2950	7630	1870	1900	1900	2100	2100
	7000	3150	8130	2070	1500	1500	1600	1600

DP/GP50CN							
Mast Type	h3	h1	h4	h2/h5	Q @ c = 500mm	Q @ c = 600mm	
	mm	mm	mm	mm	kg	kg	
Simplex	3000	2250	4130	150	5000	4500	
	3300	2400	4430	150	5000	4500	
	3700	2600	4830	150	5000	4500	
	4000	2850	5130	150	5000	4500	
	4500	3100	5630	150	5000	4500	
	5000	3350	6130	150	5000	4500	
	5500	3600	6630	150	3600	3400	
	6000	3850	7130	150	2700	2700	
Duplex	2970	2250	4100	1170	5000	4500	
	3300	2400	4410	1320	5000	4500	
	4100	2850	5210	1770	5000	4500	
Triplex	3700	2050	4830	970	5000	4500	
	4040	2170	5170	1090	5000	4500	
	4310	2260	5440	1180	5000	4500	
	4750	2400	5880	1320	5000	4500	
	5050	2500	6180	1420	5000	4500	
	5500	2650	6630	1570	3600	3500	
	6000	2850	7130	1770	2700	2700	
	6500	3050	7630	1970	2100	2100	
	7000	3250	8130	2170	1600	1600	

DP/GP50N - DP/GP55N					DP/GP50N	DP/GP55N
Mast Type	h3	h1	h4	h2/h5	Q @ c = 600mm	Q @ c = 600mm
	mm	mm	mm	mm	kg	kg
Simplex	3000	2250	4280	160	5000	5500
	3300	2400	4580	160	5000	5500
	3700	2600	4980	160	5000	5500
	4000	2850	5280	160	5000	5500
	4500	3100	5780	160	5000	5500
	5000	3350	6280	160	5000	(4800)
	5500	3600	6780	160	3400	3400
	6000	3850	7280	160	2700	(2600)
Duplex	3000	2250	4250	1030	5000	5500
	3300	2400	4560	1180	5000	5500
	4100	2850	5360	1630	5000	5500
Triplex	3700	2050	4980	830	5000	5500
	4040	2170	5320	950	5000	5500
	4310	2260	5590	1040	5000	5500
	4750	2400	6030	1180	5000	5450
	5050	2500	6330	1280	5000	(4700)
	5500	2650	6780	1430	3500	3550
	6000	2850	7280	1630	2700	(2600)
	6500	3050	7780	1830	2100	(2000)
	7000	3250	8280	2030	1700	(1550)

Mast Performance and Capacity

- h1 Height with mast lowered
- h2 Standard free lift
- h3 Lift height
- h4 Height with mast raised
- h5 Full free lift
- Q Lifting capacity, rated load
- c Load centre (distance)

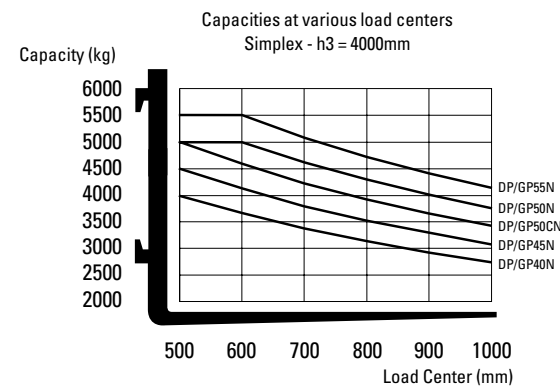

Some values for DP/GP55N are shown in brackets to highlight lower values when compared with the DP/GP50N.

catliftruck@mcf.nl
www.catliftruck.com

CEC1043(01/10)ok
Copyright ©2010, MCFE. All rights reserved.
CATERPILLAR, CAT, their respective logos,
'Caterpillar yellow' and the 'POWER EDGE' trade dress,
as well as corporate and product identity used herein,
are trademarks of Caterpillar and may not be used
without permission.
Printed in the Netherlands.

NOTE: Performance specifications may vary depending on standard manufacturing tolerances, vehicle condition, types of tyres, floor or surface conditions, applications, or operating environment. Trucks may be shown with non-standard options. Specific performance requirements and locally available configurations should be discussed with your Cat lift trucks Dealer. Cat Lift Trucks follows a policy of continual product improvement. For this reason, some materials, options and specifications could change without notice.



DP/GP40N - DP/GP45N - DP/GP50CN DP/GP50N - DP/GP55N

Specifications

Engine powered lift trucks
4.0 - 5.5 tonnes



Characteristics		Cat Lift Trucks	Cat Lift Trucks	Cat Lift Trucks	Cat Lift Trucks	Cat Lift Trucks	Cat Lift Trucks	Cat Lift Trucks	Cat Lift Trucks	Cat Lift Trucks	Cat Lift Trucks	Cat Lift Trucks	Cat Lift Trucks
1.01	Manufacturer (abbreviation)												
1.02	Manufacturer's model designation	DP40N	DP45N	DP50CN	DP50N	DP55N			GP40N	GP45N	GP50CN	GP50N	GP55N
1.03	Power source: (battery, diesel, LP gas, petrol)	Diesel	Diesel	Diesel	Diesel	Diesel			LPG	LPG	LPG	LPG	LPG
1.04	Operator type: pedestrian, (operator)-standing, -seated	Seated	Seated	Seated	Seated	Seated			Seated	Seated	Seated	Seated	Seated
1.05	Load capacity	Q (kg)	4000	4500	5000	5000	5500		4000	4500	5000	5000	5500
1.06	Load centre distance	c (mm)	500	500	500	600	600		500	500	500	600	600
1.08	Load distance, axle to fork face	x (mm)	577	577	582	602	602		577	577	582	602	602
1.09	Wheelbase	y (mm)	1850	2000	2000	2150	2150		1850	2000	2000	2150	2150
Weight													
2.01	Truck weight, without load / including battery (simplex mast, lowest lift height)	kg	5920	6330	6850	7300	7640		5860	6270	6790	7240	7570
2.02	Axle loading with maximum load, front/rear (simplex mast, lowest lift height)	kg	8960/960	9710/1130	10600/1250	11020/1280	11740/1400		8940/920	9680/1090	10570/1210	10990/1250	11710/1360
2.03	Axle loading without load, front/rear (simplex mast, lowest lift height)	kg	2630/3290	2780/3550	2900/3950	3220/4080	3170/4470		2610/3250	2750/3520	2870/3920	3190/4050	3130/4440
Wheels, Drive Train													
3.01	Tyres: V=solid, L=pneumatic, SE=solid pneumatic - front/rear		L/L	L/L	L/L	L/L	L/L		L/L	L/L	L/L	L/L	L/L
3.02	Tyre dimensions, front		8.25-15-14PR	300-15-18PR	300-15-18PR	300-15-18PR	300-15-18PR		8.25-15-14PR	300-15-18PR	300-15-18PR	300-15-18PR	300-15-18PR
3.03	Tyre dimensions, rear		7.00-12-14PR	7.00-12-14PR	7.00-12-14PR	7.00-12-14PR	7.00-12-14PR		7.00-12-14PR	7.00-12-14PR	7.00-12-14PR	7.00-12-14PR	7.00-12-14PR
3.05	Number of wheels, front/rear (x=driven)		2x/2	2x/2	2x/2	2x/2	2x/2		2x/2	2x/2	2x/2	2x/2	2x/2
3.06	Track width (centre of tyres), front	b10 (mm)	1175	1175	1175	1175	1175		1175	1175	1175	1175	1175
3.07	Track width (centre of tyres), rear	b11 (mm)	1180	1180	1180	1180	1180		1180	1180	1180	1180	1180
Dimensions													
4.01	Mast tilt, forwards/backwards	∠/β °	6/10	6/10	6/10	6/10	6/10		6/10	6/10	6/10	6/10	6/10
4.02	Height with mast lowered (see tables)	h1 (mm)	2320	2320	2400	2400	2400		2320	2320	2400	2400	2400
4.03	Free lift (see tables)	h2 (mm)	150	150	150	160	160		150	150	150	160	160
4.04	Lift height (see tables)	h3 (mm)	3300	3300	3300	3300	3300		3300	3300	3300	3300	3300
4.05	Overall height with mast raised	h4 (mm)	3920	3920	4000	4000	4000		3920	3920	4000	4000	4000
4.07	Height to top of overhead guard	h6 (mm)	2296	2296	2296	2296	2296		2296	2296	2296	2296	2296
4.08	Seat height	h7 (mm)	1280	1280	1280	1280	1280		1280	1280	1280	1280	1280
4.12	Tow coupling height	h10 (mm)	395	395	395	395	395		395	395	395	395	395
4.19	Overall length	l1 (mm)	4220	4350	4390	4530	4580		4220	4350	4390	4530	4580
4.20	Length to fork face (includes fork thickness)	l2 (mm)	3000	3130	3170	3310	3360		3000	3130	3170	3310	3360
4.21	Overall width	b1/b2 (mm)	1415/1965	1460/1965	1460/1965	1460/1965	1460/1965		1415/1965	1460/1965	1460/1965	1460/1965	1460/1965
4.22	Fork dimensions (thickness, width, length)	s, e, l (mm)	50x150x1220	50x150x1220	50x150x1220	60x150x1220	60x150x1220		50x150x1220	50x150x1220	50x150x1220	60x150x1220	60x150x1220
4.23	Fork carriage to DIN 15 173 A/B/no		3A	3A	3A	4A	4A		3A	3A	3A	4A	4A
4.24	Fork carriage width	b3 (mm)	1190	1190	1190	1190	1190		1190	1190	1190	1190	1190
4.31	Ground clearance under mast, with load	m1 (mm)	150	150	150	150	150		150	150	150	150	150
4.32	Ground clearance at centre of wheelbase, with load (forks lowered)	m2 (mm)	227	227	227	227	227		227	227	227	227	227
4.33	Working aisle width with 1000 x1200 mm pallets, crosswise	Ast (mm)	4357	4507	4542	4692	4742		4357	4507	4542	4692	4742
4.34	Working aisle width with 800 x1200 mm pallets, crosswise	Ast (mm)	4157	4307	4342	4492	4542		4157	4307	4342	4492	4542
4.35	Turning circle radius	Wa (mm)	2580	2730	2760	2890	2940		2580	2730	2760	2890	2940
4.36	Minimum distance between centres of rotation	b13 (mm)	836	903	903	971	971		836	903	903	971	971
Performance													
5.01	Travel speed, with/without load	km/h	21.5/22.0	21.0/22.0	21.0/22.0	21.0/22.0	21.0/22.0		22.0/22.5	22.0/22.5	22.0/22.5	22.0/22.5	21.5/22.5
5.02	Lifting speed, with/without load	m/s	0.55/0.61	0.55/0.61	0.47/0.53	0.47/0.53	0.47/0.53		0.57/0.60	0.57/0.60	0.49/0.52	0.49/0.52	0.49/0.52
5.03	Lowering speed, with/without load	m/s	0.50/0.50	0.50/0.50	0.50/0.50	0.50/0.50	0.50/0.50		0.50/0.50	0.50/0.50	0.50/0.50	0.50/0.50	0.50/0.50
5.05	Rated drawbar pull, with/without load	N	25000/17400	25000/18700	24700/19400	24500/21800	24200/21300		26000/17200	26000/18500	25500/19200	25500/21600	25000/21000
5.07	Gradeability, with/without load	%	26.9/26.4	24.4/26.7	22.0/25.7	20.8/26.8	19.3/25.0		27.8/25.9	25.3/26.2	22.7/25.2	21.6/26.4	19.9/24.6
5.09	Acceleration time (10 metres) with/without load	s	4.2/3.7	4.52/3.87	4.52/3.87	4.52/3.87	4.52/3.87		5.02/3.65	5.02/3.65	5.02/3.65	5.02/3.65	5.02/3.65
5.10	Service brakes (mechanical/hydraulic/electric/pneumatic)		Hydraulic	Hydraulic	Hydraulic	Hydraulic	Hydraulic		Hydraulic	Hydraulic	Hydraulic	Hydraulic	Hydraulic
I.C. Engine													
7.01	Manufacturer / Type		S6S	S6S	S6S	S6S	S6S		TB45	TB45	TB45	TB45	TB45
7.02a	Rated / Nominal output to ISO 1585	kW	57.4	57.4	57.4	57.4	57.4		68.5	68.5	68.5	68.5	68.5
7.02b	Net Power according engine label	kW	52	52	52	52	52		-	-	-	-	-
7.03	Rated speed to DIN 70 020	rpm	2300	2300	2300	2300	2300		2450	2450	2450	2450	2450
7.04	Number of cylinders / cubic capacity	/cm3	6/4996	6/4996	6/4996	6/4996	6/4996		6/4500	6/4500	6/4500	6/4500	6/4500
7.05	Fuel consumption according to VDI 60 cycle	l/h / kg/h	*	*	*	*	*		*	*	*	*	*
Miscellaneous													
8.01	Type of drive control		Powershift 2/1	Powershift 2/1	Powershift 2/1	Powershift 2/1	Powershift 2/1		Powershift 2/1	Powershift 2/1	Powershift 2/1	Powershift 2/1	Powershift 2/1
8.02	Maximum operating pressure for attachments	bar	191	191	191	191	191		191	191	191	191	191
8.03	Oil flow for attachments	l/min	-	-	-	-	-		-	-	-	-	-
8.04	Noise level, value at operator's ear (EN 12053)	dB(A)	*	*	*	*	*		*	*	*	*	*
8.05	Towing coupling design / DIN type, ref.		Pin	Pin	Pin	Pin	Pin		Pin	Pin	Pin	Pin	Pin

*Available on request

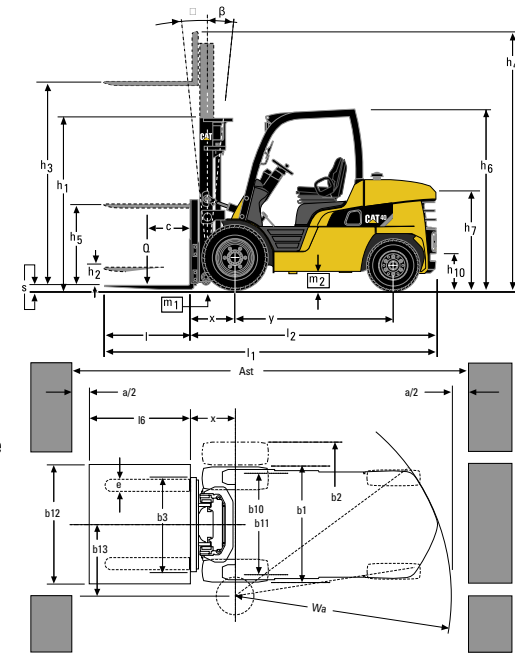

Ast = $Wa + x + l6 + a$
Ast = Working aisle width with load
a = Safety clearance (200 mm)
l6 = Pallet length (800 or 1000 mm)
b12 = Pallet width (1200 mm)

Lower Cost of Ownership

- Specially positioned air intake system lengthens the life of air intake filter cartridges.
- LCD multi functional display with indicators providing all safety functions, allows for rapid trouble shooting.
- Long service interval.
- Fingertip hydraulic mast control.
- Durable transmission system giving smooth and accurate gear changes and low noise levels.
- Highly regarded, market proven industrial diesel and LPG engines give excellent performance.
- LED lights and LED front / rear combination lights.

Unmatched Productivity

- Engine hour's timer keeps track of hours worked helping fleet managers to schedule regular maintenance.
- Compact design through all the range which increases maneuverability in space restricted areas.
- Cooling system designed to reduce blockages utilising pusher type radiator airflow.
- Wide variety of mast types and lifting heights allows the truck to be specified to your needs.
- High capacity ratings.
- Full floating power line featuring two forward speeds and one speed reverse with high gradeability and travel speed.
- Hydrostatic steering system makes maneuvering the truck light and easy.

- 5.5 tonnes capacity model gives greater versatility to satisfy customer requirements.

Safety and Ergonomics

- PDS+, presence detection system disengages drive and hydraulic functions when the operator's seat is vacated.
- Electronic button operated parking brake.
- Operator identification system with Pin-code standard.
- Handgrip mounted at the rear of the overhead guard with a horn button contributes to reduce back strain and fatigue in applications with repetitive reversing.
- Hydraulic controlled drum brake system for increased safety.
- Adjustable steering column for comfortable operation.

Options

- Electronic controlled diesel engine.
- Ground speed control.
- Load indicator on Simplex masts.
- "Dust prevention" and "Clogging prevention" packages.
- Panel cabin.
- Full tiltable cabin.
- Complete range of attachments.

